

Service Manual

THE FISHER®

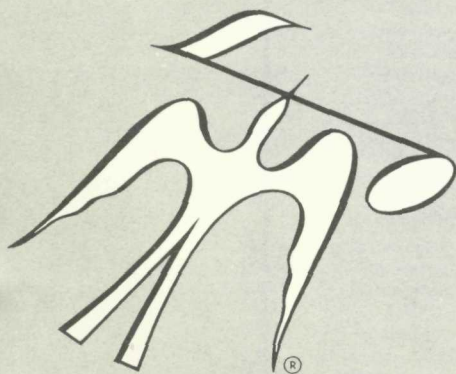
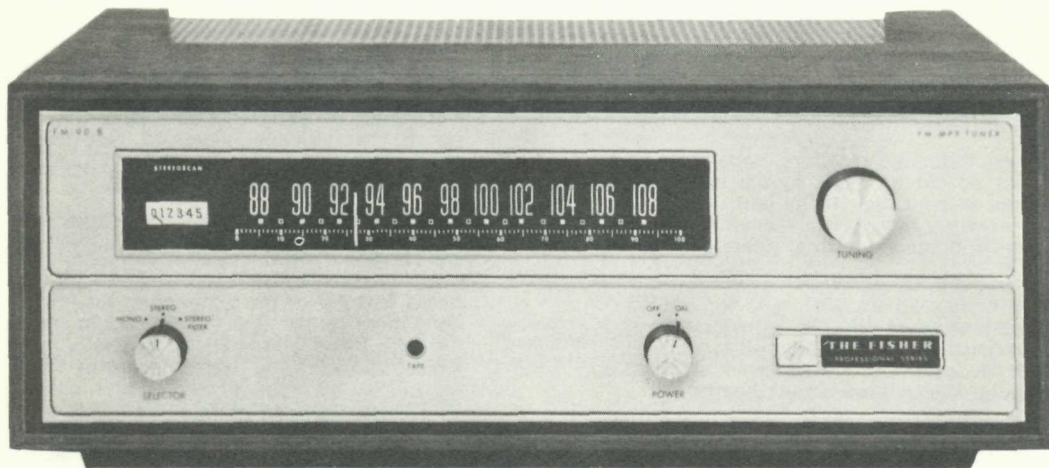

FM-90-B

CHASSIS SERIAL NUMBERS
BEGINNING 22001

\$1.00

FISHER RADIO CORPORATION • LONG ISLAND CITY 1 • NEW YORK

CAUTION: This is a FISHER precision high-fidelity instrument. It should be serviced only by qualified personnel—trained in the repair of transistor equipment and printed circuitry.

EQUIPMENT AND TOOLS NEEDED

The following are needed to completely test and align modern high-fidelity instruments such as amplifiers, tuners and receivers.

Test Instruments

Vacuum-Tube Volt-ohmmeter DC VTVM
Audio (AC) Vacuum-Tube Voltmeter (AC VTVM)
Oscilloscope (Flat to 100 kc minimum)
Audio (Sine-wave) Generator
Intermodulation Analyzer
Sweep (FM) Generator (88 to 108 mc)
Marker Generator
Multiplex Generator (preferably with RF output—
FISHER Model 300 or equal).

Miscellaneous

Adjustable-Line-Voltage Transformer or
line-voltage regulator
Load Resistors (2)—8-ohm, 50-watt (or higher)
Stereo source (Turntable with stereo cartridge
or Tape Deck)
Speakers (2) Full-range, for listening tests
Soldering iron (with small-diameter tip)
fully insulated from power line.

PRECAUTIONS

Many of the items below are included just as a reminder—they are normal procedures for experienced technicians. Shortcuts can be taken but often they cause additional damage—to transistors, circuit components or the printed-circuit board.

Soldering—A well-tinned, hot, clean soldering iron tip will make it easier to solder without damage to the printed-circuit board or the many many circuit components mounted on it. It is not the wattage of the iron that counts—it is the heat available at the tip. Low-wattage soldering irons will often take too long to heat a connection—pigtail leads will get too hot and damage the part. Too much heat, applied too long, will damage the printed-circuit board. Some 50-watt irons reach temperatures of 1,000° F—others will hardly melt solder. Small-diameter tips should be used for single solder connections—larger pyramid and chisel tips are needed for larger areas.

- When removing defective resistors, capacitors, etc., the leads should be cut as close to the body of the circuit component as possible. (If the part is not being returned for in-warranty factory replacement it may be cut in half—with diagonal-cutting pliers—to make removal easier.)
- Special de-soldering tipleths are made for unsoldering multiple-terminal units like IF transformers and electrolytic capacitors. By unsoldering all terminals at the same time the part can be removed with little chance of breaking the printed-circuit board.
- Always disconnect the chassis from the power line when soldering. Turning the power switch OFF is not enough. Power-line leakage paths, through the heating element, can destroy transistors.

- Use care when making connections to speakers and output terminals. Any frayed wire ends can cause shorts that may burn out the output transistors—they are direct-coupled to the speakers. There is no output transformer—nothing to limit current through the transistors except the fuses. To reduce the possibility of shorts at the speakers, lugs should be used on the exposed ends—at least the ends of the stranded wires should be tinned to prevent frayed wire ends. The current in the speakers and output circuitry is quite high. Any poor contact or small-size wire, can cause power losses in the speaker system. Use 14 or 16 AWG for long runs of speaker-connecting wiring.

DC-Voltage Measurements—These basic tests of the transistor circuitry are made without the signal generator. Without any signal input measure the circuit voltages—as indicated on the schematic. The voltage difference between the base and the emitter should be in the millivolt range—a sensitive DC meter is needed for these readings. A low-voltage range of 1 volt, full scale—or lower—is needed.

Audio-Voltage (gain) Measurements—The schematic and printed-circuit board layout diagrams are used. Input signals are injected at the proper points—found most quickly by using layout of the printed-circuit board instead of the schematic. An AUDIO (AC) VTVM connected to the test points should indicate voltages close to those values shown in the boxes on the schematic. Many of the signal levels in the input stages are only a few millivolts—they can not be read on the AC ranges supplied on most Vacuum-Tube AC/DC Volt-ohmmeters (VTVMs). Even with a 1-volt range a signal level of 100 millivolts (.1 volt) will be the first 1/10 of the meter scale. A reading of 1 millivolt (.001 volt) will hardly even move the meter needle.

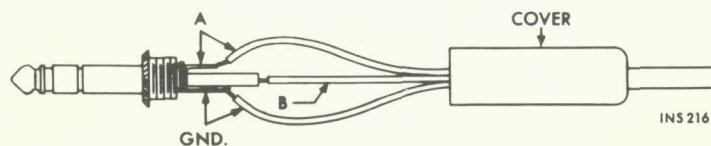

CONNECT A TO HOT TERMINAL OF LEFT CHANNEL
HIGH-LEVEL INPUT; B TO HOT TERMINAL OF
RIGHT CHANNEL HIGH-LEVEL INPUT;
GND TO GROUND SIDE OF BOTH INPUTS

Wiring of Tape Jack Connector

P1034-2 FRONT END

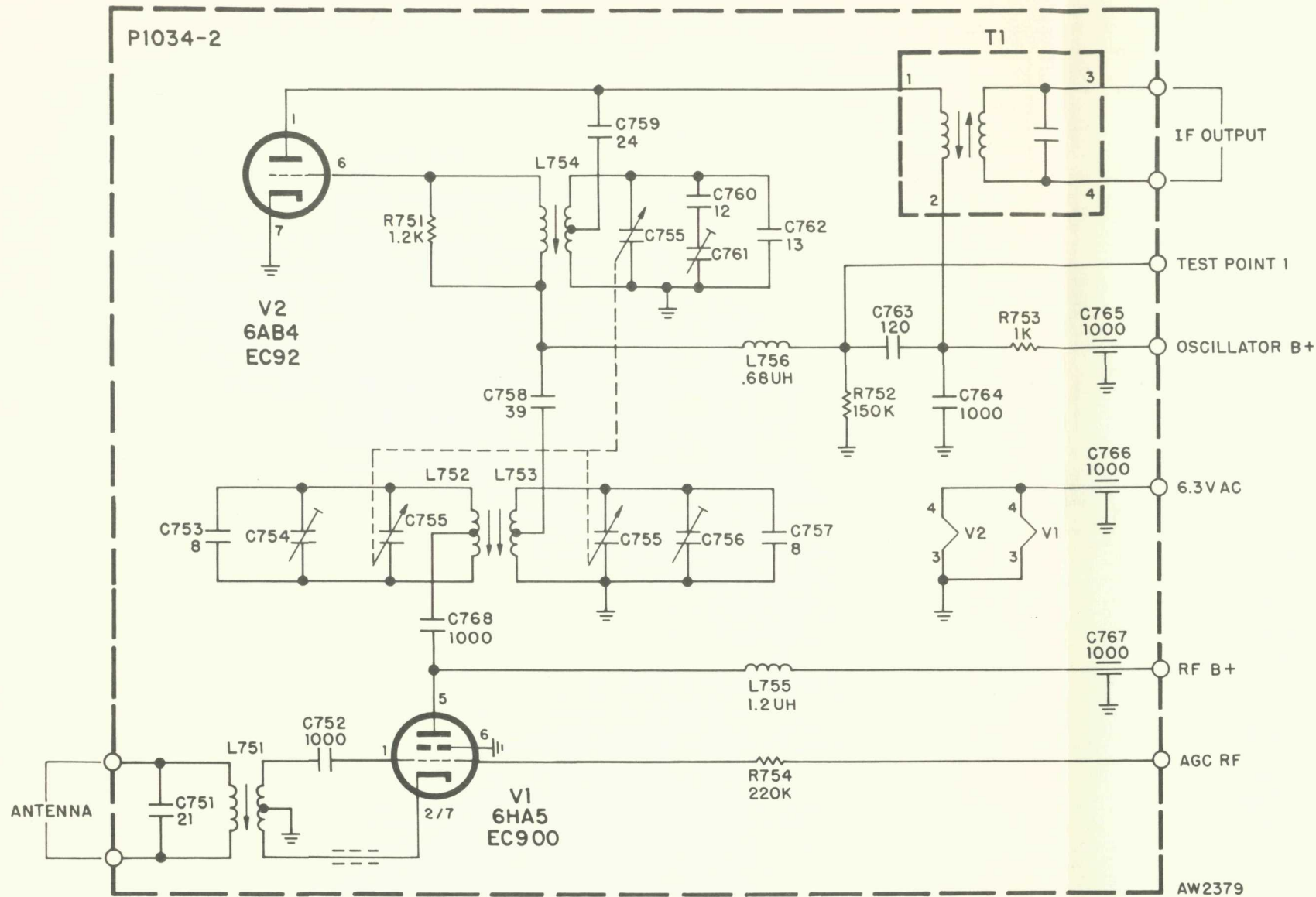

PARTS DESCRIPTION LIST

CAPACITORS		
Symbol	Description	Part No.
C751	Ceramic 21pF, 5%, N750, 1000V	C50070-32
C752	Ceramic, 1000pF, GMV, 500V	C50089-2
C753	Ceramic, 8pF, 5%, NPO, 1000V	C50070-45
C754	Ceramic, Trimmer	C662-123
C755	Variable, FM Tuning	C966-109-1
C756	Ceramic, Trimmer	C662-123
C757	Ceramic, 8pF, 5%, NPO, 1000V	C50070-45
C758	Ceramic, 39pF, 10%, N1500, 1000V	C50070-17
C759	Ceramic, 24pF, 5%, N150, 1000V	C50070-8
C760	Ceramic, 12pF, N080, 5%, 500V	CC20LJ120J5
C761	Ceramic, Trimmer	C662-123
C762	Ceramic, 13pF, NPO, 5%, 500V	CC20CJ130J5
C763	Ceramic, 120pF, 5%, N1500, 1000V	C50070-44
C764	Ceramic, 1000pF, 10%, 1000V	C50072-3
C765, 766, 767	Ceramic, Feedthru, 1000pF	C592-187
C768	Ceramic, 1000pF, GMV, 500V	C50089-2
RESISTORS		
R751	Dep. Carbon 1.2K, 5%, 1/8W	R12DC122J
R752	Dep. Carbon 150K, 5%, 1/8W	R12DC154J
R753	Dep. Carbon 1K, 5%, 1/8W	R12DC102J
R754	Dep. Carbon 220K, 5%, 1/8W	R12DC224J
COILS, CHOKES, TRANSFORMERS		
L751	Coil, FM Antenna	L966-113
L752	Coil, R. F.	L1034-113
L753	Coil, F. M. Mixer	L1034-112
L754	Coil Assembly, Oscillator	AS1034-115
L755	Choke, 1.2 Microhenry	L50066-3
L766	Choke, .68 Microhenry	L50066-1
T1	Transformer, FM I.F.	ZZ50210-20

DIAL STRINGING PROCEDURE

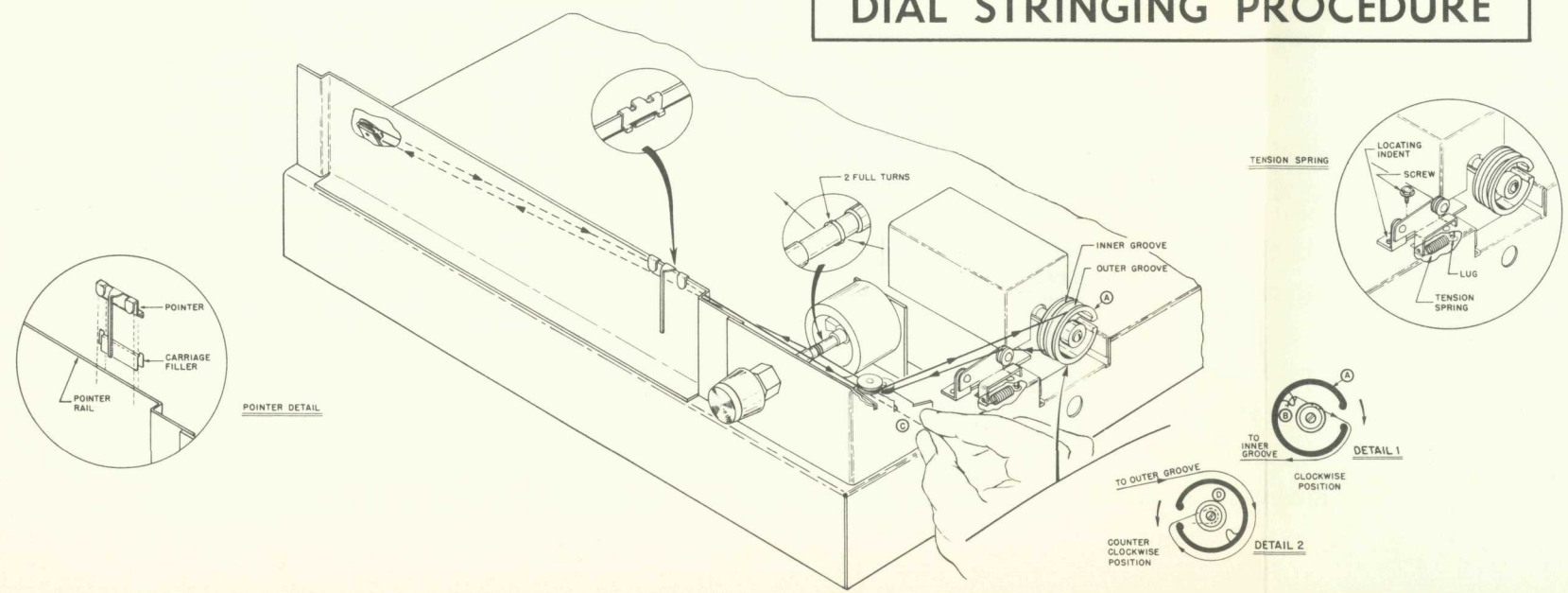

- 1-Rotate drive drum A (on tuning-capacitor shaft) to its maximum clockwise position.
- 2-Tie dial cord to ear B (inside drum A) as shown in Detail 1.
- 3-Run dial cord through slot in rim of drum A.
- 4-Set dial cord in INNER groove and over tension-spring pulley.
- 5-String dial cord, as shown, to point C.
- 6-Hold dial cord taut with left hand.
- 7-Wind drum A to maximum counterclockwise position (with right hand).
- 8-Wrap loose end of dial cord around drum A, in outer groove, as shown in Detail 2 (using right hand).
- 9-Secure loose end of dial cord under machine screw and washer (D) in the center of the drive drum.

P 1131-2 SCHEMATIC DIAGRAM • MULTIPLEX SECTION

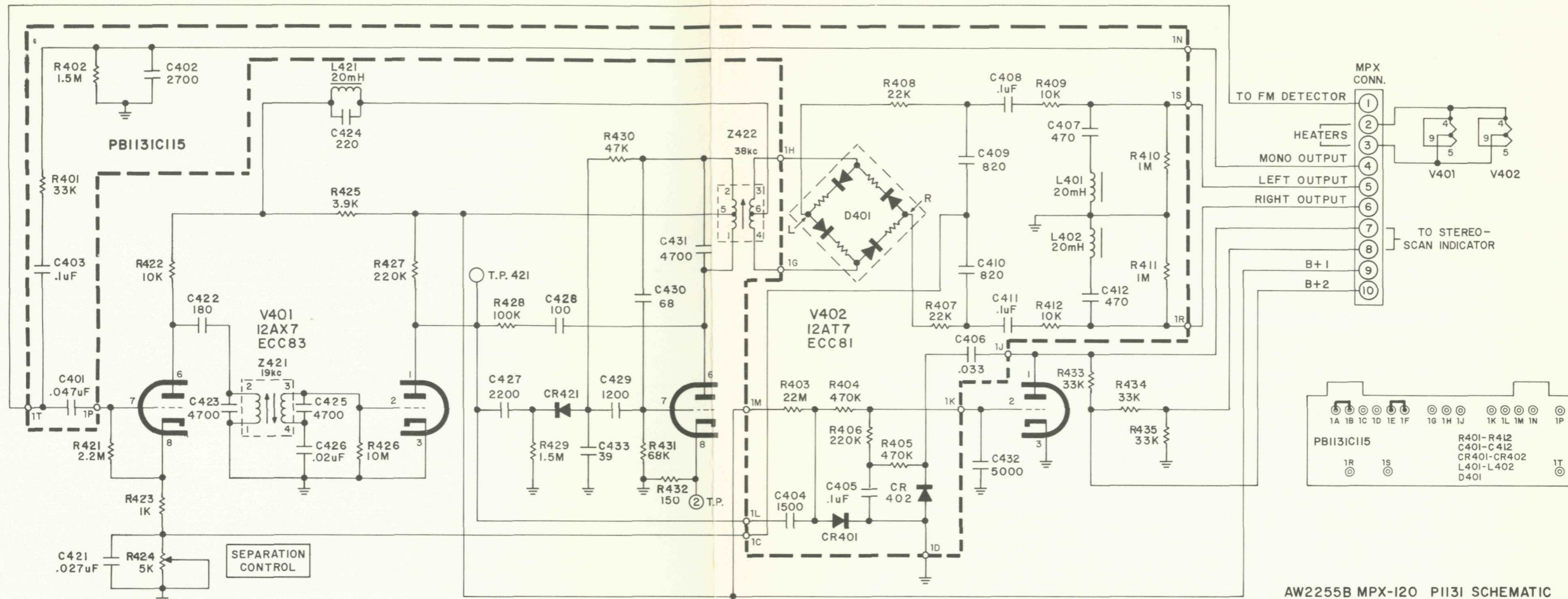

AW2255B MPX-I20 P1131 SCHEMATIC

PARTS DESCRIPTION LIST

All circuit components with symbols beginning with 401 are located on the printed-circuit board; those beginning with 421 are mounted on the metal subchassis.

CAPACITORS

20% tolerance for all fixed capacitors, unless otherwise noted or marked GMV (guaranteed minimum value). All capacitors not marked uF are pF (uuf).

Symbol	Description	Part No.
C401	Capacitor, Mylar, .047uF 10% 100V	C50B574-5
C402	Capacitor, Polystyrene, 2700 5% 125V	C50B634-20
C403	Capacitor, Plastic Film, .1uF 20% 250V	C50B633-1
C404	Capacitor, Cer. Disc., 1500, 10%	C50B576-4
C405	Capacitor, Plastic Film, .1uF 20% 250V	C50B633-1
C406	Capacitor, Plastic Film, .033uF 20% 400V	C50B633-20
C407	Capacitor, Cer. Disc, 470 pF 10%	C50B576-1
C408	Capacitor, Plastic Film, .1uF 20% 250V	C50B633-1
C409	Capacitor, Cer. Disc, 820 10%	C50B576-3
C410	Capacitor, Cer. Disc, 820 10%	C50B576-3
C411	Capacitor, Plastic Film, .1uF 20% 250V	C50B633-1
C412	Capacitor, Cer. Disc, 470 pF, 10%	C50B576-1
C421	Mylar, .027 uF, 5%, 100V	C50B574-6
C422	Polystyrene, 180, 5%, 500V	C50B634-1

Symbol	Description	Part No.
C423	Polystyrene, 4700, 5%, 125V	C50B634-21
C424	Polystyrene, 220, 5%, 500V	C50B634-2
C425	Polystyrene, 4700, 5%, 125V	C50B634-21
C426	Ceramic, .02 uF, +80, -20%, 500V	C50089-4
C427	Ceramic, 2200, 20%, 1000V	C50183-10
C428	Ceramic, 100, 20%, 1000V	C50183-9
C429	Ceramic, 1200, 10%, 1000V	C50183-8
C430	Ceramic, 68, 10% NPO, 1000V	C50070-46
C431	Mica, 4700, 5%, 300V	C50332-7
C432	Ceramic, 5000, 20%, 500V	C50089-1
C433	Ceramic, 39, 10%, N1500, 1000V	C50070-17

RESISTORS

Symbol	Description	Part No.
R401	Resistor, Dep. Carbon, 33k 5%, 1/8W	R12DC333J
R402	Resistor, Dep. Carbon, 1.5m, 5%, 1/3W	R33DC155J
R403	Resistor, Composition, 22M, 10%, 1/2W	RC20BF226K
R404	Resistor, Dep. Carbon, 470k, 5%, 1/8W	R12DC474J
R405	Resistor, Dep. Carbon, 470k, 5%, 1/8W	R12DC474J
R406	Resistor, Dep. Carbon, 470k, 5%, 1/8W	R12DC224J
R407	Resistor, Dep. Carbon, 22k, 5%, 1/8W	R12DC223J
R408	Resistor, Dep. Carbon, 22k, 5%, 1/8W	R12DC223J
R409	Resistor, Dep. Carbon, 10k, 5%, 1/8W	R12DC103J
R410	Resistor, Dep. Carbon, 1m, 5%, 1/8W	R12DC105J

Symbol	Description	Part No.
R411	Resistor, Dep. Carbon, 1m, 5%, 1/8W	R12DC105J
R412	Resistor, Dep. Carbon, 10k, 5%, 1/8W	R12DC103J
R421	Dep. Carbon, 2.2M, 5%, 1/3W	R33DC225J
R422	Dep. Carbon, 10K, 5%, 1/3W	R33DC103J
R423	Dep. Carbon, 1K, 5%, 1/3W	R33DC102J
R424	Potentiometer, 5K Separation Control	R50150-11
R425	Dep. Carbon, 3.9K, 5%, 1/3W	R33DC392J
R426	Composition, 10M, 10%, 1/2W	RC20BF106K
R427	Dep. Carbon, 220K, 5%, 1/3W	R33DC224J
R428	Dep. Carbon, 100K	R12DC104J
R429	Dep. Carbon, 1.5M, 5%, 1/3W	R33DC155J
R430	Dep. Carbon, 47K, 5%, 1/3W	R33DC473J
R431	Dep. Carbon, 68K	R12DC683J
R432	Dep. Carbon, 150, 5%, 1/3W	R33DC151J
R433, 434, 435	Composition, 33K, 10%, 1W	RC30BF333K

MISCELLANEOUS

Symbol	Description	Part No.
CR401	Diode	V111W
CR402	Diode	V50A260-15
CR421	Diode	V1112
D401	Ring Demodulator	V50A260-18
L401	Coil	L50334-2
L402	Coil	L50334-2
L421	Coil, 20 uH	L50334-2
Z421	Transformer, 19 kc	ZZ50210-34
Z422	Transformer, 38 kc	ZZ50210-54
-	Printed Circuit Bd.	PB1131B111
-	Mini. Pin Term.	A50A577
-	Sleeving 23-32" Lg.	E50A684-4

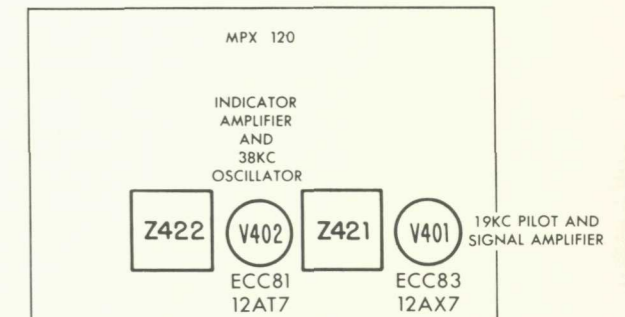

P1131-2 MULTIPLEX DECODER

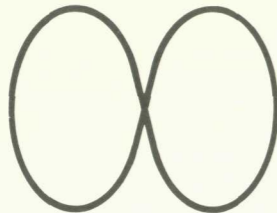

FIGURE 1. Lissajous pattern for MPX Oscillator alignment.

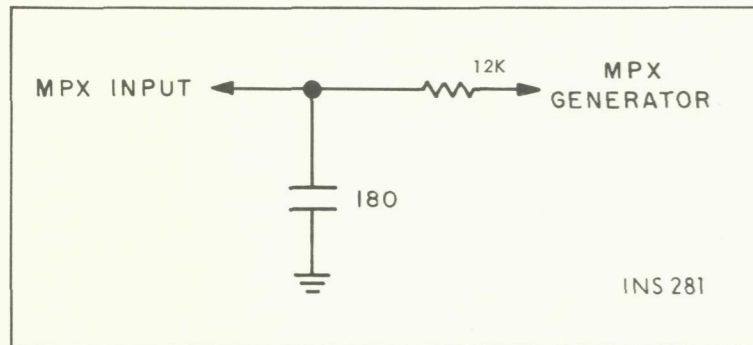
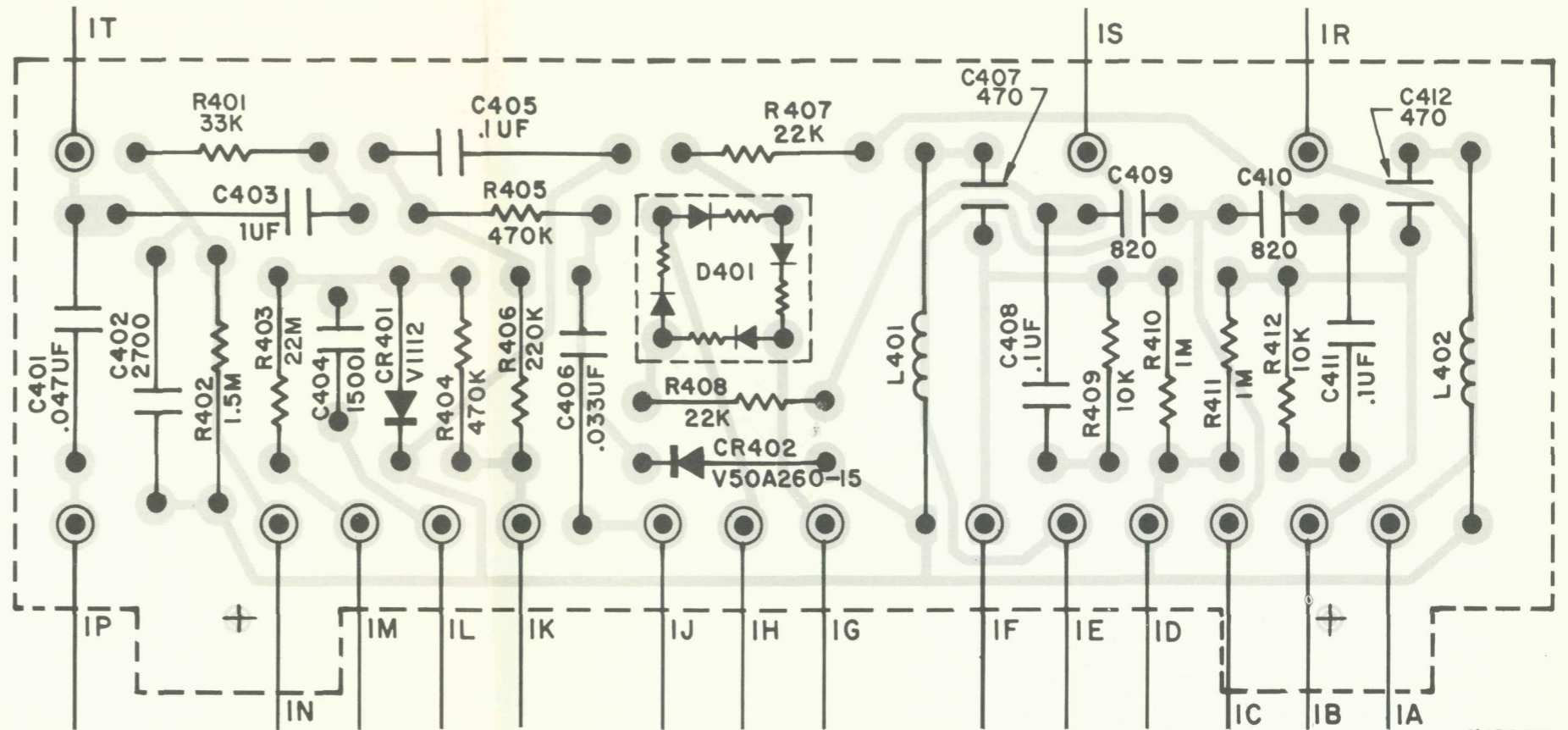

FIGURE 2. Multiplex-alignment hi-pass filter circuit.



ALIGNMENT INSTRUCTIONS • MULTIPLEX SECTION

GENERAL

The preferred alignment procedure, in table 1 below, uses a multiplex generator with an RF output, like the FISHER Model 300. Optimum performance will be obtained only when the multiplex decoder is connected to the FM detector with which it will be used. Check IF alignment first—poor alignment can prevent proper multiplex decoder operation.

TEST EQUIPMENT REQUIRED: MULTIPLEX GENERATOR, AUDIO (AC) VTVM, 100 KC OSCILLOSCOPE WITH EXTERNAL SWEEP JACKS, ALIGNMENT TOOL.

TABLE 1

STEPS	GENERATOR		R F DEVIATION	INDICATOR	ALIGNMENT	
	CONNECTION	MODULATION		TYPE AND CONNECTION	ADJUST	INDICATION
1	Multiplex generator RF output to antenna terminals	19 kc pilot only	± 7.5 kc	VTVM to TP 1	Z 421 top and bottom	Maximum reading on VTVM
2	19 kc output of generator to oscilloscope horizontal input; generator not connected to MPX section	—	—	Vertical input of oscilloscope to TP 2; set oscilloscope for external sweep	Z 422	Set frequency of free-running oscillator as close as possible to 38 kc. Lissajous pattern (see figure 1) should be as slow-moving as possible.
3	Same as Step 1	Composite MPX; 1000 cps on left channel only	± 75 kc	VTVM and oscilloscope vertical input to right channel output lug (terminal 1R)	Z 421 top	Maximum reading on VTVM; clean 1000 cps sine wave on oscilloscope
4	Same as Step 1	Composite MPX; 1000 cps on right channel only	± 75 kc	Same as Step 3	MPX separation control (R 424)*	Minimum reading on VTVM should be at least 33 db below reading obtained in Step 3
5	Same as Step 1	Same as Step 4	± 75 kc	VTVM and oscilloscope vertical input to right channel output lug (terminal 1S)	—	Same VTVM reading as obtained in Step 3 ± 2 db; clean 1000 cps sine wave on oscilloscope
6	Same as Step 1	Composite MPX; 1000 cps on left channel only	± 75 kc	Same as Step 5	MPX separation control (R 424), if necessary*	Minimum reading on VTVM should be at least 33 db below reading obtained in Step 5.

* If adjustment is required, adjust for best compromise readings in Steps 4 and 6.

ALTERNATE ALIGNMENT PROCEDURE

For multiplex generators without an RF output

When using this alignment procedure, it is necessary to disconnect the ratio detector from the multiplex decoder at the point where the generator is connected. Unsolder point IT carefully. The generator input must be through a simple low-pass filter—a 12 K resistor between the multiplex generator and the MPX input with a 180 pF capacitor from the MPX input end of the resistor to ground (Figure 2, on schematic).

TEST EQUIPMENT REQUIRED: MULTIPLEX GENERATOR, AUDIO (AC) VTVM, 100 KC OSCILLOSCOPE WITH EXTERNAL SWEEP JACKS, ALIGNMENT TOOL.

TABLE 2

STEPS	GENERATOR			INDICATOR	ALIGNMENT	
	CONNECTION	AUDIO	LEVEL		ADJUST	INDICATION
1	Composite output of MPX generator to input of MPX demodulator (Point 1)	19 kc pilot only	100 mV RMS (280 MV P-P)	AC VTVM to TP 1	Z 421 top and bottom	Maximum reading on VTVM
2	19 kc output of generator to oscilloscope horizontal input; generator not connected to MPX section	—	—	Oscilloscope vertical input to TP 2	Z 422	Set frequency of free-running oscillator as close as possible to 38 kc. Lissajous pattern (see figure 1) should be as slow-moving as possible.
3	Same as Step 1	1000 cps on left channel only	0.7 V RMS (3.92 V P-P)	AC VTVM and oscilloscope vertical input to left channel output lug (terminal 1R)	Z 421 top	Maximum reading on VTVM; clean 1000 cps sine wave on oscilloscope
4	Same as Step 1	1000 cps on right channel only	0.7 V RMS (3.92 V P-P)	Same as Step 3	MPX separation control (R 424)*	Minimum reading on VTVM should be at least 33 db below reading obtained in Step 3
5	Same as Step 1	Same as Step 4	0.7 V RMS (3.92 V P-P)	VTVM and oscilloscope vertical input to right channel output lug (terminal 1S)	—	Same VTVM reading as obtained in Step 3 ± 2 db; clean 1000 cps sine wave on oscilloscope
6	Same as Step 1	1000 cps on left channel only	0.7 V RMS (3.92 V P-P)	Same as Step 5	MPX separation control (R 424), if necessary*	Minimum reading on VTVM should be at least 33 db below reading obtained in Step 5.

* If adjustment is required, adjust for best compromise readings in Steps 4 and 6.

MAIN CHASSIS SCHEMATIC DIAGRAM

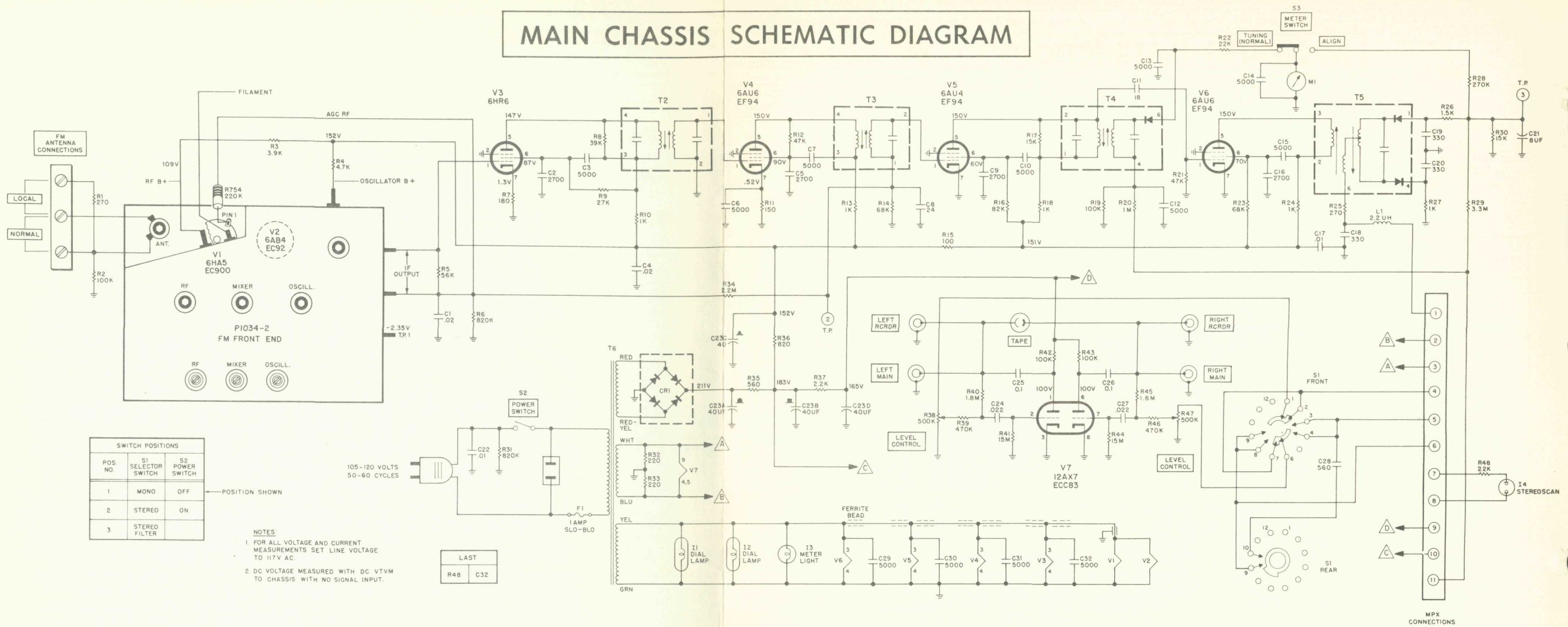

SWITCH POSITIONS		
POS. NO.	S1 SELECTOR SWITCH	S2 POWER SWITCH
1	MONO	OFF
2	STEREO	ON
3	STEREO FILTER	

NOTES:
 1. FOR ALL VOLTAGE AND CURRENT MEASUREMENTS SET LINE VOLTAGE TO 117V AC.
 2. DC VOLTAGE MEASURED WITH DC VTVM TO CHASSIS WITH NO SIGNAL INPUT.

LAST	
R48	C32

PARTS DESCRIPTION LIST

CAPACITORS

10% Tolerance for all fixed Capacitors, unless otherwise noted or marked GMV (Guaranteed minimum value). All Capacitors not marked uF are pF(uuF).

Symbol	Description	Part No.
C1	Ceramic, .02uF +80-20 100V	C50095-1
C2	Ceramic, 2700, 100V	C50072-17
C3	Ceramic, 5000, +80-20, 500V	C50089-6
C4	Ceramic, .02uF, GMV, 1000V	C50071-6
C5	Ceramic, 2700, 1000V	C50072-17
C6, 7	Ceramic, 5000, +80-20, 500V	C50089-6
C8	Ceramic, 24, 5%, 1000V, N150	C50070-8
C9	Ceramic, 2700, 1000V	C50072-17
C10	Ceramic, 5000, +80-20, 500V	C50089-6
C11	Ceramic, 18, 5%, 1000V, N150	C50070-30
C12, 13		
14, 15	Ceramic, 5000, +80-20, 500V	C50089-6
C16	Ceramic, 2700, 1000V	C50072-17
C17	Ceramic, .01, 20%, 500V	C50089-3
C18, 19, 20	Ceramic, 330, 1000V	C50072-1
C21	Electrolytic, 8uF, 50V	C629-138
C22	Molded, .01uF, 20%, 600V	C2747
C23	Electrolytic, 4-Section: A-40uF, 300V B-40uF, 300V C-40uF, 250V D-40uF, 250V	C670-125B

C24	Mylar, .022uF, 400V	C50B574-8
C25, 26	Mylar, .1uF, 10%, 400V	C50B574-10
C27	Mylar, .022uF, 400V	C50B574-8
C28	Ceramic, 560, 1000V	C50072-14
C29, 30		
31, 32	Ceramic, 5000, +80-20, 500V	C50089-6

RESISTORS

Composition, in ohms, 10% tolerance, 1/2 watt unless otherwise noted. K = Kilohm, M = Megohm.

Symbol	Description	Part No.
R1	270	RC20BF271K
R2	100K	RC20BF104K
R3	3.9K, 10%, 1 Watt	RC30BF392K
R4	4.7K	RC20BF472K
R5	56K	RC20BF563K
R6	820K	RC20BF824K
R7	180	RC20BF181K
R8	39K	RC20BF393K
R9	27K	RC20BF273K
R10	1K	RC20BF102K
R11	150	RC20BF151K
R12	47K	RC20BF473K
R13	1K	RC20BF102K
R14	68K	RC20BF683K
R15	100	RC20BF101K
R16	82K	RC20BF823K

R17	15K	
R18	1K	
R19	100K	
R20	1M	
R21	47K	
R22	Dep. Carbon, 22K, 5%, 1/3W	
R23	68K	
R24	1K	
R25	270	
R26	1.5K	
R27	1K	
R28	270K	
R29	3.3M	
R30	15K	
R31	820K	
R32, 33	220	
R34	2.2M	
R35	Glass, 560, 10%, 5W	
R36	W. W., 820, 10%, 3W	
R37	W. W. 2.2K, 10%, 3W	
	Potentiometer, 500K, Level Control	
R38		
R39	Dep. Carbon, 470K, 5%, 1/8W	
R40	Dep. Carbon 1.8M, 5%, 1/3W	
R41	15M	
R42, 43	Dep. Carbon, 100K, 5%, 1/3W	
R44	15M	
R45	Dep. Carbon, 1.8M, 5%, 1/3W	
R46	Dep. Carbon, 470K, 5%, 1/8W	

RC20BF153K	
RC20BF102K	
RC20BF104K	
RC20BF105K	
RC20BF473K	
R33DC223J	
RC20BF683K	
RC20BF102K	
RC20BF271K	
RC20BF152K	
RC20BF102K	
RC20BF274K	
RC20BF335K	
RC20BF153K	
RC20BF824K	
RC20BF221K	
RC20BF225K	
RPG5W561K	
RPG3W821K	
RPG3W222K	

R47	Potentiometer, 500K, Level Control	R50103-6
R48	22K	RC20BF223K
MISCELLANEOUS		
Symbol	Description	Part No.
CR1	Diode, Selenium Rectifier	SR50279-1
F1	Fuse, 1 Amp. Slo-Blo	F692-132
I1, I2	Lamp, Dial	I50441-1
I3	Lamp, Meter #1847 O.F.	I50009-8
I4	Stereoscan Indicator	I50621-3
L1	Choke, 2.2 Microhenry	L50066-6
M1	Meter	M946-213
S1	Switch, Selector	S1126-126
S2	Switch, Power	S50358-7
S3	Switch, Meter	S50200-2
T2	Transformer, FM IF	ZZ50210-39
T3	Transformer, FM IF	ZZ50210-2
T4	Coil, Limiter	ZZ50210-61
T5	Transformer, Ratio Detector	ZZ50210-2
T6	Transformer, Power	T1126-115
	Antenna, FM Dipole	A550227-1
	Insert, Dress Panel Screened (Upper)	AS1126-122
	Insert, Dress Panel Screened (Lower)	AS1126-123
	Knob, Selector, Power	E50562-1
	Knob, Tuning	E50566-2
	Jack, Tape Recorder	J50545
	Dial Glass	N1126-107

ALIGNMENT INSTRUCTIONS

Read these instructions very carefully before attempting alignment.

Set the SELECTOR switch to the MONO position.

Set tuning dial to the extreme low-frequency position. (Dial pointer should line up with the calibration mark at the low-frequency end of the dial scale. Reset the dial pointer if necessary.)

Warm up the chassis and the test equipment for at least 15 minutes.

Adjust line voltage (power input to chassis) for 117 volts AC 50 to 60 cycles.

(Use only the proper, fully insulated, alignment tools.) Reduce signal generator output during alignment to keep VTVM reading below that specified for step 1.

Repeat steps 4 and 5 to obtain proper dial calibration and maximum sensitivity.

STEP	DIAL	SIGNAL GENERATOR			DC VTVM	ADJUST	INDICATION
		GENERATOR COUPLING	FREQ.	MOD.			
1	Set dial pointer for extreme low-frequency position.	Ungrounded tube shield of V2	10.7 MC	None	Test Point 3*	T1, T2, T3, T4, and T5 top and bottom	Maximum negative voltage (below 20 volts)
2		Ungrounded tube shield of V2	10.7 MC	None	Hot lead of DC VTVM to TEST POINT 4. Ground lead of DC VTVM to junction of two series-connected external resistors (47K 5%), wired between TEST POINT 3 and ground.	T5 top	Zero indication on zero-center dial.
3	90 MC	Two 120-ohm carbon resistors in series with generator leads to the NORMAL antenna terminals (Figure 1).	90 MC	± 22.5 KC deviation at 400 cps.	Through 100K resistor to Test Point 2	L4, L3 and L2	Adjust for maximum negative voltage and check for sinusoidal waveform, with scope, at LEFT or RIGHT RCRDR output.
4	106 MC		106 MC	± 22.5 KC deviation at 400 cps.	Through 100K resistor to Test Point 2	C13, C7 and C4	
5	98 MC		98 MC	± 22.5 KC deviation at 400 cps.	Through 100K resistor to Test Point 2	L1	

* METER SWITCH: In the ALIGN position the TUNING INDICATOR meter is connected to TEST POINT 3 and may be used in place of a DC VTVM. The switch should be returned to the NORMAL position afterward.

TUNER MAINTENANCE

CLEANING THE DIAL GLASS

(1) Remove the front panel: Disconnect the set from AC power as a precaution. Remove all knobs, and remove the hex nuts on the control shafts. Lift off the front panel.

(2) Loosen the screws that retain the clips to the dial glass. (When you replace the dial glass, make certain to reset it by placing it firmly against the lower left-hand corner. Swing the retaining clips aside, and carefully lift off the dial glass.

(3) Remove dust with a dry rag. If you wish to clean more thoroughly, use a soap and water solution only; if you use any stronger cleaning agent, you may damage the markings on the glass.

REPLACING DIAL LAMPS

First, disconnect the AC power cord as a precaution. Remove the front panel as described above. The lamps are held in place by spring clips and can be removed with the fingers. Replace with a new lamp from your FISHER Dealer (Part Number I-50441-1).

If replacement parts are out of stock, locally, they may be obtained directly from the Parts Department of FISHER Radio Corporation. They will be shipped "best way", either prepaid or C.O.D. unless otherwise specified.

For instrument-operation information and technical assistance write Richard Hamilton, Customer Service Department, FISHER Radio Corporation, Long Island City, New York 11101.

COMPONENT CONNECTION

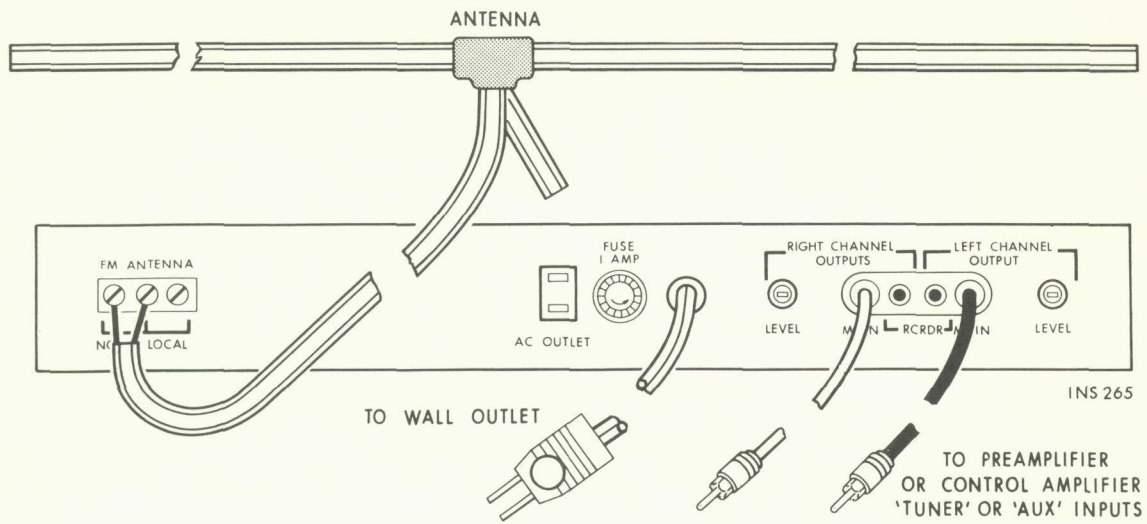

TUBE LAYOUT

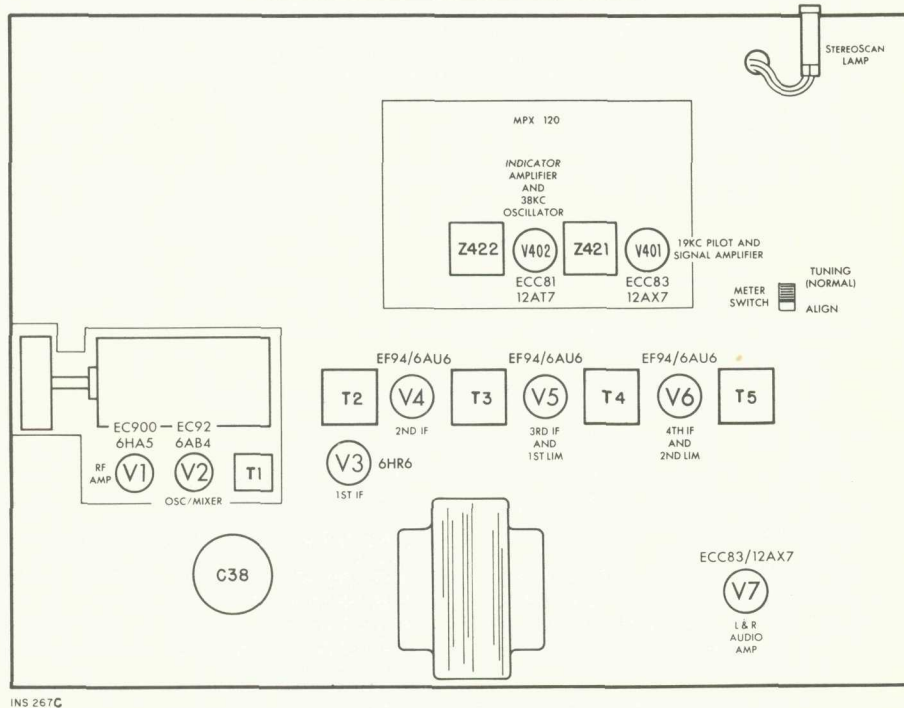

FISHER RADIO CORPORATION • NEW YORK